

Hot Runner Controller AK60

Instruction Manual

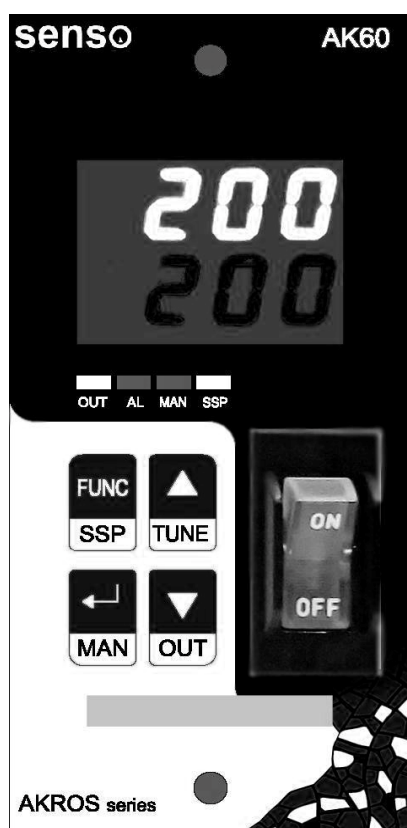

sensio

INDEX

1. INTRODUCTION	3
1.1. General specifications	3
2. INPUT / OUTPUT.....	4
2.2. Input Setup.....	4
2.2. Alarm.....	4
3. AUTOTUNING	7
3.1. Step Response Autotuning	7
3.2. Relay Feedback Autotuning	8
4. CURRENT MEASUREMENT	9
5. OPERATION.....	10
5.1. Introduction.....	10
5.2. Description of the front panel	12
5.3. Start-up	12
5.4. Power loss	13
5.5. Description of all the configurable parameters.....	14
5.6. General diagram of menus.....	17
5.7. Keyboard lock	20
6. TECHNICAL SPECIFICATIONS	21
7. ERROR AND ALARM MESSAGES	22
8. GUARANTEE AND SERVICE	23

1. INTRODUCTION

This instruction manual describes how to install and start up the AK60 hot runner controller.



You must read the instruction manual before starting up the equipment.

1.1. General specifications

The model AK60 is a high-performance process controller specifically designed for temperature control in hot runner systems. Its most outstanding features are as follows:

- Input:

Thermocouple type J: 0...600°C (Fe-CuNi, IEC584)

Thermocouple type K: 0...1200°C (NiCr-NiAl, IEC584)

- Control output by triac of 3500W.
- PID or PI+D (PI with automatic derivative) control type with 2 different types of autotuning algorithms user-selectable depending on the application.
- Automatic or Manual working mode.
- Double large digit display.
 - 4 digits of 10 mm for the process variable.
 - 4 digits of 10 mm for the Set Point.
- Protection temperature alarm with internal power stop (Optional)
- Supply: 85...265 Vac 50/60 Hz.

2. INPUTS / OUTPUTS

2.1. Signal input

Input signal must be selected setting the parameter **IRP**.

Thermocouple type J: 0...600°C (Fe-CuNi, IEC584)

Thermocouple type K: 0...1200°C (NiCr-NiAl, IEC584)

2.2. Alarm

The model AK60 can be fitted with 2 alarm. The alarm output is by relay with SPST contacts (a voltage-free contact).

Configuration depends on parameters **EA1** y **EA2**.

1) Set point.

Absolute Set Point (**SPA1** y **SPA2**): The activating / deactivating point of the alarm is independent of the value of the process set point. For example, if an alarm Set Point of 200°C is configured, the alarm will change status at that temperature, regardless of the value of the pre-set temperature for the process (process Set Point).

Current setpoint (**CSP1**, **EA1**, **CSP2**, **EA2**): The activating / deactivating point of the alarm is referred to the current measured at the heating element. If this value is out of the range [CSPx-Crx,CSPx+Crx] alarm is activated. All those values are independent on the working setpoint. All those values are independent on the working setpoint. For instance if **CSP1** is set to 1,2A and **EA1** is set to 0.3A, alarm will change its state if current measured is over 1.5A or under 0.9A.

Relative Set Point (**rA1** y **rA2**): The activating / deactivating point of the alarm is always linked to the value of the process set point. For example, if a relative Set Point of 20°C is configured, the alarm's status change point will always be 20°C higher than the Set Point of the process. With a Set Point of 100°C for the process, the alarm is set at 120°C. With a Set Point of 250°C, the alarm will be set at 270°C.

Window Set Point (**rA1** y **rA2**): The activating / deactivating point of the alarm becomes a symmetrical value, both above and below the process Set Point. For example, with a window Set Point of 10° for the alarm and a process Set Point of 50°C, the alarm will change status at 40°C and 60°C. With a process Set Point of 250°C, the alarm will change status at 240°C and 260°C.

2) Enabling type.

High alarm: The alarm is triggered when the process variable is greater than the alarm set point. For example, if the alarm's Set Point is at 250°C, the alarm will remain activated as long as the process is above this temperature.

Low alarm: The alarm is triggered when the process variable is less than the alarm set point. For example, if the alarm's Set Point is at 250°C, the alarm will remain activated as long as the process is below this temperature.

Window alarm: The alarm remains activated as long as the process variable is outside a certain value around the process Set Point, both above and below it. For example, if the process has a Set Point of 200°C and the alarm a window signal of 30°C, the alarm will be triggered whenever the process is below 170°C and above 230°C.

Current alarm: The alarm activates when the measured current de salida is out of range regarding the currentg setpoint, either above or under. For instance if **CSPI** is set to 1,2A and **Cr** is set to 0.3A,

alarm will change its state if current measured is over 1.5A or under 0.9A.

CA1 / CA2	Working mode
OFF	Alarm off
Hi	Absolute setpoint, high
Lo	Absolute setpoint, low
rHi	Relative Set Point, high
rLo	Relative Set Point, low
Wind	Window alarm
Curr	Window current alarm

The alarm type of action is controlled by the parameter **Act1** and **Act2**:

Direct Action (**dir**): The output relay is normally deactivated and is enabled when the enabling condition of the alarm occurs.

Reverse Action (**rev**): The output relay is normally activated and is disabled when the enabling condition of the alarm occurs.

3. AUTOTUNING

Autotune type can be selected through parameter **Aut**

3.1. Step Response autotuning.

The autotuning process is a very useful function for determining the values of **Pb**, **ti** and **td** which will give the process the greatest stability.

Step Response autotuning takes place below the set point and it can only be enabled if the process variable is less than 50% of the set point value. This process consists of supplying 100% power and disabling the output when the process is at around 80% of the signal. Next, the controller measures the inertia of the process and deduces the values of the PID parameters for the process in question.

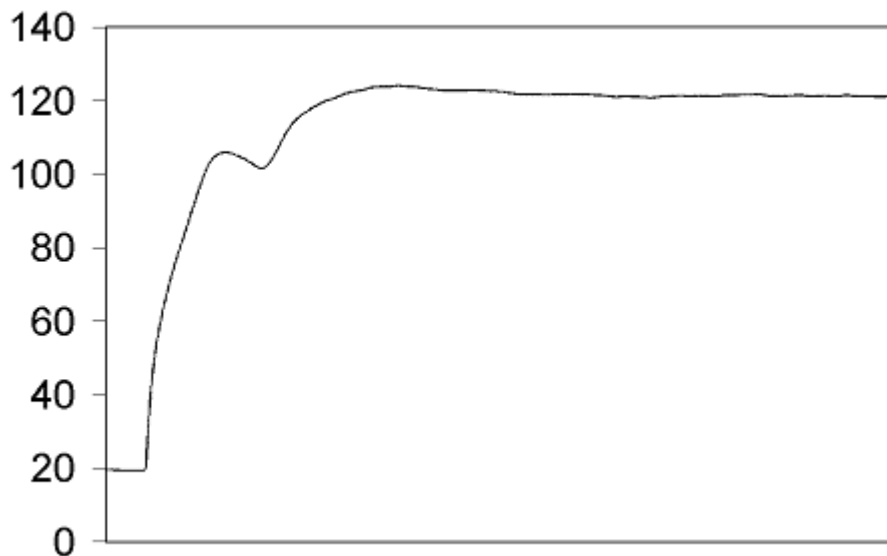

3.2. Relay Feedback autotuning.

Relay feedback autotuning has the advantage that it takes place on the set point and can be enabled at any time. However, it has the drawback that, to perform the tuning, the process has to exceed the signal several times and there may be cases where this is unwise, due to damages that could occur in the process.

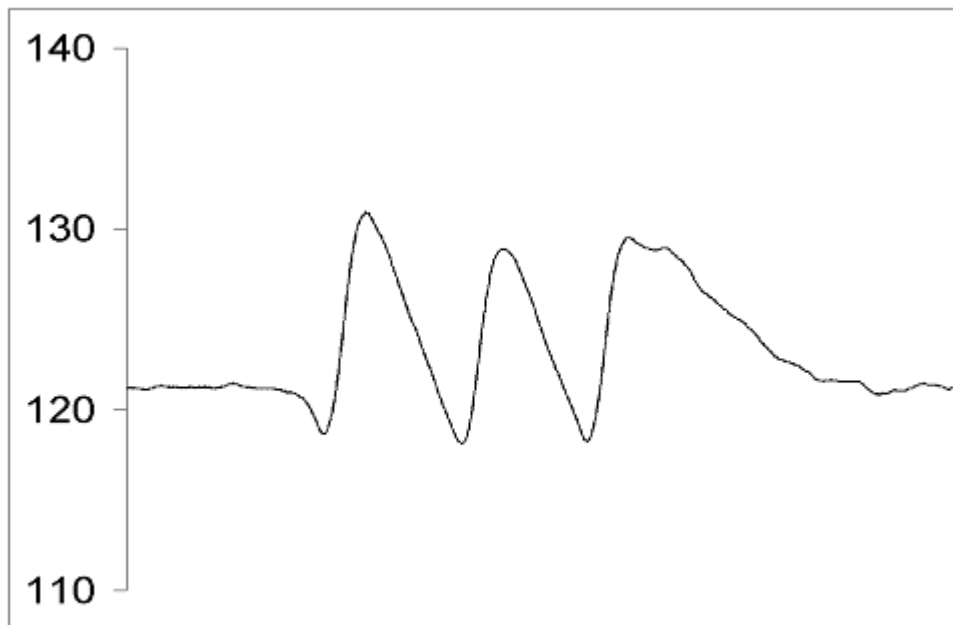

4. MEDIDA DE CORRIENTE

AK60 is able to measure power or current consumption using a toroidal transformer. Current measure can be activated setting parameter **AMP** to on. Once done, current measurement parameters will be available.

The end of scale of the measurement can be selected to 25A or 50A using parameters **SELA**.

To be able to measure current, AK60 needs to supply output pulses of at least 300ms. If output power provides output pulses shorter than this for more time than **CYA** x (Control Cycle), a 300ms pulse will be forced to allow a valid measure.

The parameter **DISP** allows to setup which value is shown on display. Values available are **AMP** (current) and **POWER** (power). If power is selected, the line voltage can be setup trough parameter **LINE**.

5. OPERATION

5.1. Introduction



Akros series instruments are fully configurable. This feature means there are a large number of configuration parameters. In order to make it easier to program the parameters, for each instrument, only those parameters which, because of their configuration, are available.

Point 5.5 describes all the configurable parameters and point 5.6 sets out the route to be followed to access each of the parameters in graphic form.

The configuration menus have been arranged in 3 levels:

- Level 1** The configuration parameters of the work mode appear, but not those affecting the instrument's configuration.
- Level 2** At this level, the instrument's configuration parameters not depending on the physical configuration (inputs and outputs) are configured.
- Level 3** At this level, the instrument is configured by specifying values affecting the input and output signals.

Operation of the instrument is arranged with 4 keys, the functions of which are as follows:

Tecla	Función
	Function key. It enters to instrument menus when pressed once. Once there is inside the menu, it goes to next level menu when pressed during 2 seconds. Key SSP. If instrument is working in normal mode, this key allows activating the secondary setpoint by holding this key during two seconds.
	Enter key. It should be pressed in order to save changes to any parameter.
	Man key. It should be pressed during two seconds in order to switch working mode from automatic to manual (and reverse way). In manual working mode, the power output can be varied by keys ▼ y ▲.
	Key Up. It is used to increment a parameter value. If it is hold, the variation of the parameter increases. Key Tune. It should be pressed during two seconds in order to activate autotuning process. It will be executed when it is possible to activate autotuning depending on parameter 8834 .
	Tecla Down. It is used to decrement a parameter value. If it is hold, the variation of the parameter decreases. Key Out. In normal operation mode, it switches the display to show setpoint, power output (P) or current measured (A o u (if power is cosen)).

5.2. Description of the front panel

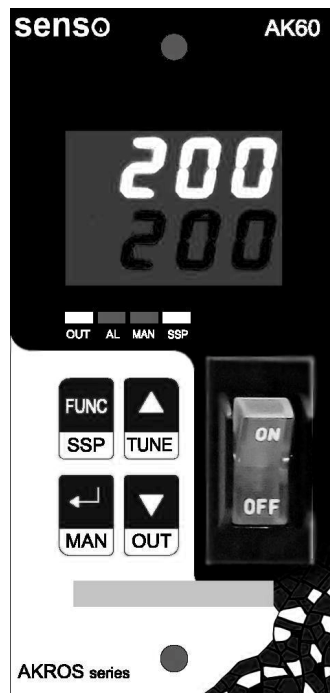

There are also the following indicator lights:

- | | |
|---------------|--|
| OUT | Control or heating output |
| AL | Lights up if any alarm is active |
| MAN | Lights up when the instrument is working in manual mode |
| SSP | Lights up when the secondary Set Point is enabled |
| | Switch 16 A with a magnetothermic that serves as a protection of the load and the regulator. If current is over 16 A, magnetothermic acts and leave the device inactive. |
| ON/OFF | If the regulator is on, switch shows the power output through a pilot. |

5.3. Start-up

When connecting the power supply voltage, the instrument displays the message “TEST ON” while the controller initiates all the internal parameters.

5.4. Power loss





















































When the instrument loses the power supply voltage, all the parameters remain stored in the instrument's internal memory. When the power is restored, the controller will re-start control of the process using the function configured in parameter **SEFn** (**nOnE**, **EuNE**, **NaN**).

5.5. Description of all the configurable parameters

Símbolo	Descripción	Valor	Fábrica
SP	Setpoint of the process	From SPLL To SPHL	150
Pb	Proporcional band	From 0.1% To 100.0%	2,5
t_i	Integral time	From 1s To 4000s	320
t_d	Derivative time	From 1s To 4000s	60
Cy	Cycle of control output	From 1s To 120s	1
CA1	Configuration of the work mode alarm 1	OFF : disabled Hi : Absolute high alarm	OFF
Act1	Alarm 1 actuator direction	dir : Relay is normally open rev : relay is normally closed	dir
SPA1	Absolute Alarm 1 Setpoint	From SPLL To SPHL	155
HYA1	Alarm 1 Hysteresis	From 0 To 9999	1
CA2	Configuration of the work mode alarm 2	OFF : Disabled Hi : Absolute high alarm Lo : Absolute low alarm rHi : Relative high alarm rLo : Relative low alarm Wind : Window alarm Curr : Window current alarm	OFF
Act2	Alarm 2 actuator direction	dir : Relay is normally open rev : Relay is normally closed	dir
SPA2	Absolute Alarm 2 Setpoint	From SPLL To SPHL	155
rA2	Relative Alarm 2 Setpoint	From -999 To 9999	5
CSP2	Setpoint of current regarding alarm 2	Only last value of measured current can be assigned	0
r2	Relative setpoint of current regarding window alarm 2	From 0,1 To 50,0	0,5
HYA2	Alarm 2 hysteresis	From 0 To 9999	1

Serie Akros

senso

	Mask alarm 2	From 0 To 1	1
	Secondary Setpoint	From  To 	100
	Bias (value added to measured control variable)	From -999 To 9999	0
	Temperature units	 	
	Control Output top limit	From 0 To 100	100
	High limit of setpoint value	From  +1 To high input signal value	600
	Low limit of setpoint value	From low input signal value To  -1	0
	Autotune type	 : relay feedback  : step response	
	Start up function	 : No special function  : Autotune on startup  : Manual mode on startup	
	Value of power output at startup if the startup function is 	From 0 To 	100
	Control type	 : control PID  : control PI+D	
	End of preheating	From  To 	120
	Input sensor type	 : Thermocouple J  : Thermocouple K	
	Modbus address of the device	From 1 To 255	1
	ModBus baudrate	 : 2400 bps  : 4800 bps  : 9600 bps  : 19200 bps  : 38400bps  : 56000bps  : 57600bps	
	Parity	 : No parity  : Even parity  : Odd parity	
	ModBus delay	From 0ms To 10ms	5

Serie Akros

senso

ANP

Current measure enable

On : Enable
OFF : Disable

OFF

d.SP

Value showed in the display

ANP : Show current
POWER : Show power

ANP

Line

Voltage line

From 100
 To 265

220

CYA

Maximum number of power output cycles among current measures

From 0
 To 120

30

LEVL

Keyboard protection level

FREE : Unlocked
SP : Only allowed Setpoint
SP A : Only allowed SP and alarm
LoCH : Everything locked

FREE

Code

Keyboard protection code

From 0
 To 9999

0

5.6. General diagram of menus

Level 1

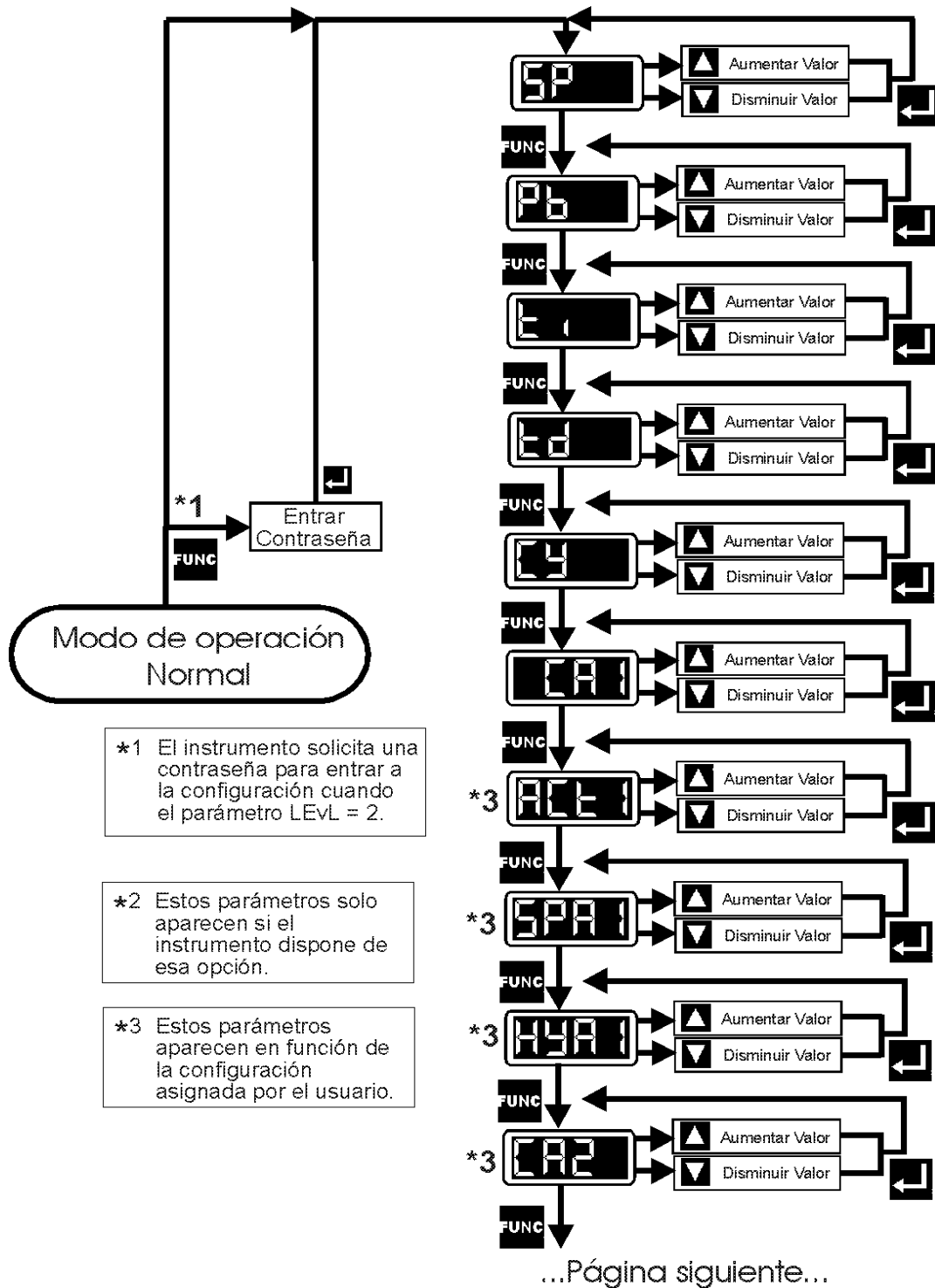

Level 2

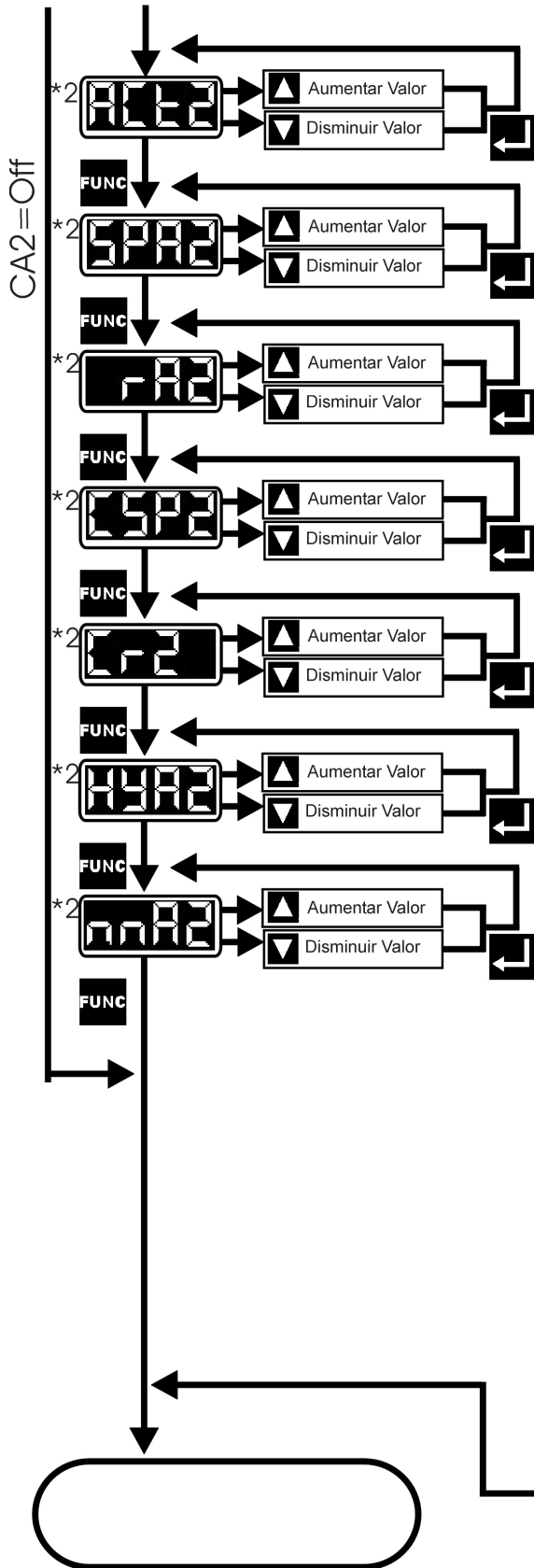

Manteniendo pulsada la tecla FUNC desde el nivel 1.

Nivel 2

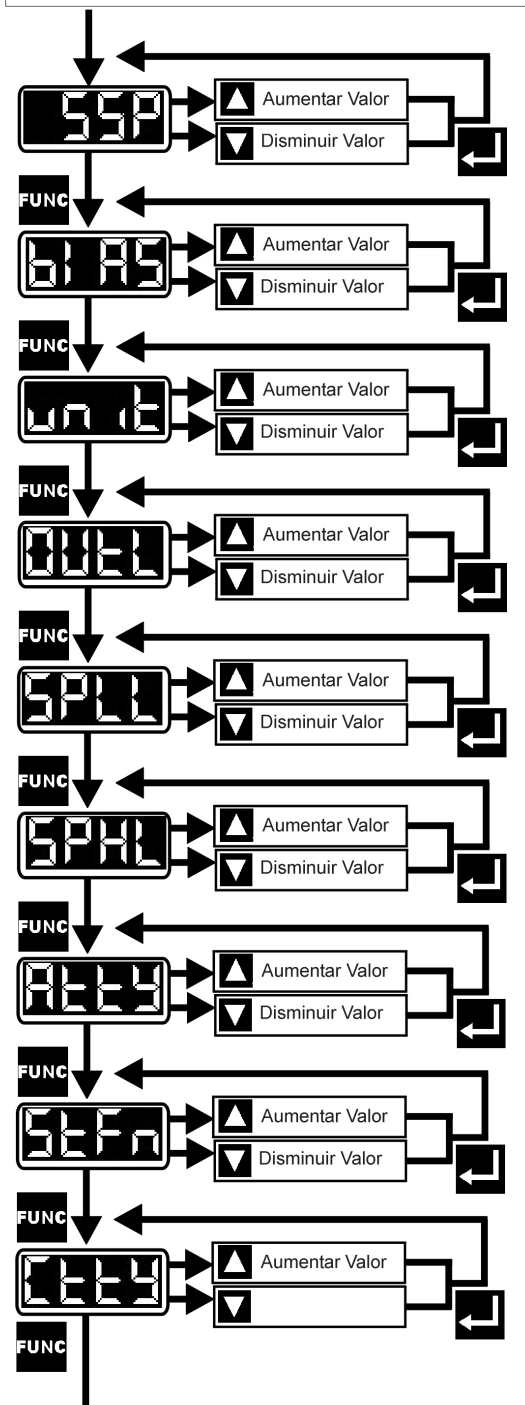

Level 3

Manteniendo pulsada la tecla FUNC desde el nivel 2.

Nivel 3

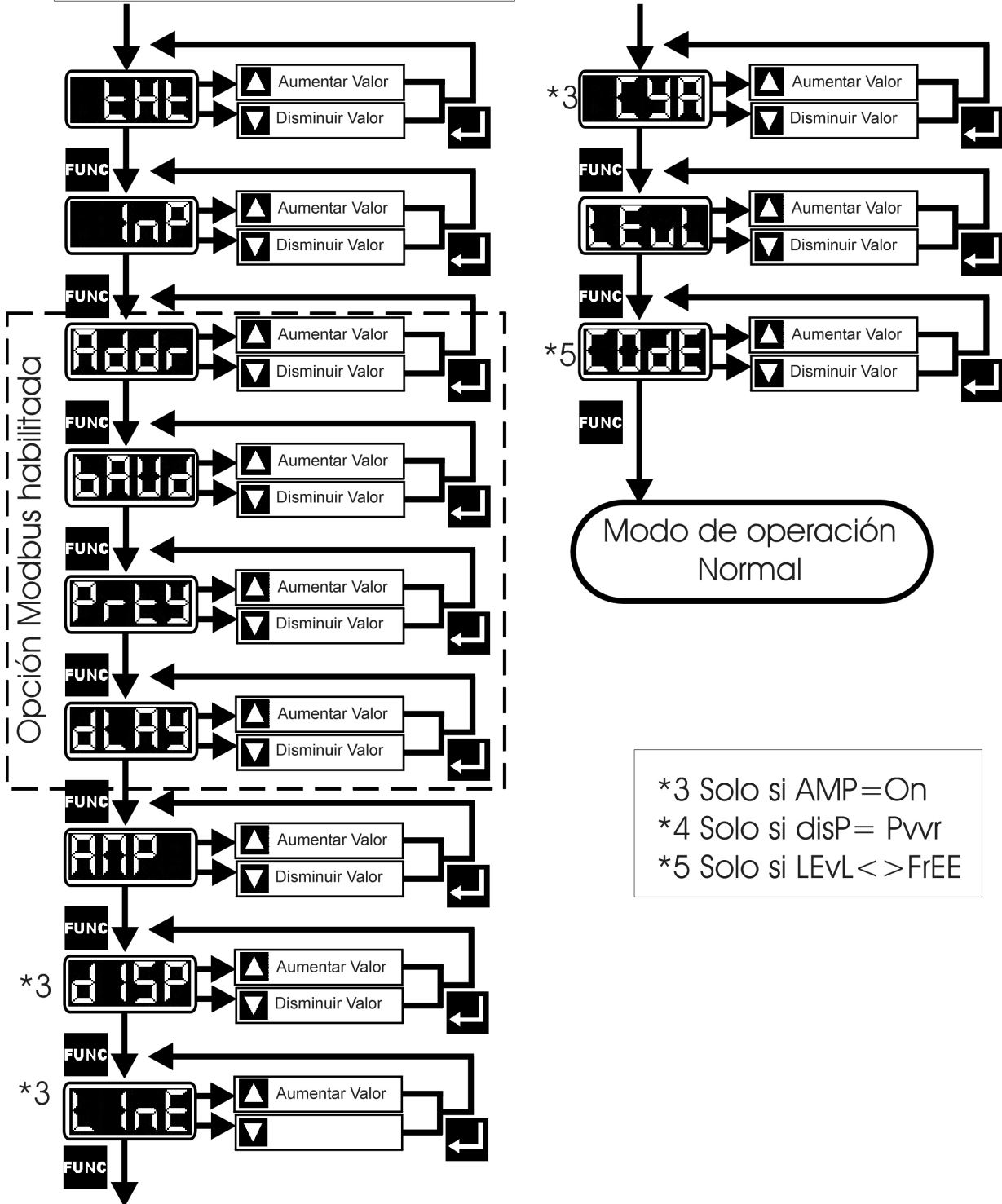

5.7 Keyboard lock

The keyboard can be locked entering a password to the **CODE** parameter or through the digital input. If keyboard lock is configured using digital input code will not be available. Keyboard can be locked. Level of protection is selected with parameter **LEV**:

FrEE	Unlocked
SP	Only the Set Point can be modified. Password is required to access the rest of parameters
SP A	Only the Set Point and alarm setpoint can be modified. Password is required to access the rest of parameters
LoCK	It is not possible to see and modify any parameter without password

If keyboard lock is setup using parameter **LEV**, controller will ask for password. When password is required, message **PASS** is shown and code can be set digit by digit. To select next digit use key **MAN**. Once desired code is set press **FUNC SSP**. Next parameter will be shown if code is correct. **LoCK** message will be shown if password is not correct.

6. TECHNICAL SPECIFICATIONS

Size	Plug-in in RACK format EuroCard 100x160mm
Power supply	85..265 Vca 50/60 Hz
Consumption	8 VA
Atmos. Temp.	0..50°C (interior use)
Relative humidity	máx. 80% non condensing
Altitude	máx. 2000 m
Installation Cat.	II as per EN61010-1
Degree of pollution	I as per EN61010-1
Display	4 digits of 10 mm for the process variable 4 digits of 10 mm for the signal
Input	J : 0..600°C (Fe-CuNi, IEC584) K: 0..1200°C (NiCr-NiAl, IEC584)
Precision	± 0,25% v.f.e
Control Output	Triac of 3500W
Alarm	Over temperatura protection with power intern stop protection. (Opcional)
Type of control	PID or PI+D, with 2 autotuning algorithms.
CE certification (for both industrial and commercial environments)	<ul style="list-style-type: none"> • Seguridad: EN61010 • EMI susceptibility: EN50082-1 <ul style="list-style-type: none"> • EN61000-4-2, descargas electrostáticas • EN61000-4-3, campos radiados • EN61000-4-4, transitorios • EN61000-4-5, onda de choque • EN61000-4-6, corrientes inyectadas • EN61000-4-8, campo magnético • EN61000-4-11, interrupciones de tensión • EMI emission: EN50081-1 <ul style="list-style-type: none"> • EN55022-b, conducted emissions • EN55022-b, radiated emissions • Harmonics: EN61000-3-2 • Voltage fluctuations: EN61000-3-3

7. ERROR AND ALARM MESSAGES

Akros series modules can show different error or warning messages.

Ad
Err

Error in the unit's internal electronics. If this message appears, the instrument must be sent to your nearest distributor for repair.

Mem
Err

Error in the unit's internal memory. If this message appears, the instrument must be sent to your nearest distributor for repair.

Over

The circuit of the input signal has been broken or else the input signal is over the top limit.

Under

The input signal is below the bottom limit of the scale, or else the connections are inverted.

A 22

There is no current measurement sample acquired. This message can be shown for instance, while autotune is on because current sensing is suspended in order to don not interfere with the process.

P 22

It appears in case that the power is shown instead of current.

8. GUARANTEE AND SERVICE

This instrument is guaranteed against all kinds of manufacturing defect or faults in its component parts for one year as from the date of purchase. This guarantee includes repair or replacement of the faulty parts in our factory, free of charge, unless the fault is caused by mishandling of the equipment or any component of it has been changed.

Instruments requiring service or repair should be sent to your nearest distributor.

MILPUNTS S.L.
Camí del Mig, 62 - 64, Carrer D - 15B
08349 - Cabrera de Mar - Barcelona
T.(+34) 93 759 38 85
F.(+34) 93 759 37 24
www.senso.es