



## Specifications

### Electric power supply

230..240 Vac + PE 50/60Hz with 3 meter cable with Shuko plug

### Switches

The controller has a general 16 A switch and a 16A breaker switch which eliminates the need of the power fuses. No spare fuses will be needed.

### Thermocouple input

Thermocouple is the most standard input

As a default: J : 0..600°C (Fe-CuNi , IEC584)

Configurable: K: 0..1200°C (Ni-NiCr, IEC584)

Cold junction compensation accuracy: better than 0,5° C after 30 minutes.

Measuring units: °C or °F

Measurement Accuracy: better than +/- 0,25% FSV

### RTD input

The RTD/Pt100 is an also available temperature sensor.

Range: 0..600°C

### Power and wiring output

The heating output and the sensor connection is made via a 6 ways multipole connector.

The maximum allowed power to the heater is 3500W or 16 Amp.

### Room conditions

Working: 0..50°C

Storage: -10..60°C

Humidity: 0..95 % HR non condensing.

### Dimensions

88 x 222 x 225 mm (high x wide x deep)

### CE conformity (in industrial and commercial environment)

Safety: EN61010

Immunity EMI: EN50082-1

EN61000-4-2, electrostatic discharges

EN61000-4-3, radiated fields

EN61000-4-4, burst

EN61000-4-5, surge

EN61000-4-6, injected currents

EN61000-4-8, magnetic field

EN61000-4-11, PQT

EMI emission: EN50081-1

EN55022-b, conducted

EN55022-b, radiated

The AK53 model is a compact equipment for temperature control applications with a well proven pre-heating algorithm and a 3500W power capacity

## General description

The AK53 is a single zone temperature controller with a very well proven pre-heating algorithm specifically designed by SENSO for the temperature control of hot runner systems. It also has the autotuning feature to calculate the best suitable PID parameters for each application.

The input can be chosen between different thermocouple types and also RTD. It has a large and clear display and 4 function keys for its easy configuration.

The electric actuator is a well cooled solid state relay with a PWM output specifically designed by SENSO for the temperature control of hot runner systems and to assure a proper and efficient dehumidifying process.

Electrical input is through a 3 meter cable and the output is via a multipole connector with both sensor and power I/O.

**NO SPARE FUSES NEEDED.** The front switch breaker eliminates the need of spare fuses which simplifies the system maintenance.

## Protection switch

Beside the general switch in the back of the controller, the system has a protection breaker switch at the front which eliminates the need of spare fuses. This clever design simplifies the maintenance procedures.

## Auto / Manual

Switching to manual mode can be very helpful when the thermocouple is broken. Also during the mould setup, switching to manual can help in checking the wiring.

## Secondary setpoint

The Secondary Setpoint can be activated by means of a front key. This option allows the user to change the control set point to a standby temperature.

## Control

### PID control

The temperature control is performed by the AK53 controller through DC pulses which are only 10 ms in duration. The advanced PWM (Pulse Wave Modulator) algorithm ensures that during the preheating phase only half periods are applied to the load. On the PID control mode, the controller output is the result of the three control actions added: Proportional, Integral and Derivative. The controller output will vary from 0 to 100% as a result of this combination.

## Preheating

### Preheating for injection moulding systems

The AK53 model has an advanced automatic pre-heating algorithm whose aim is the elimination of the humidity absorbed by the heating elements. The controller doses the output power in order to slowly increase the process temperature without harming the heating element.

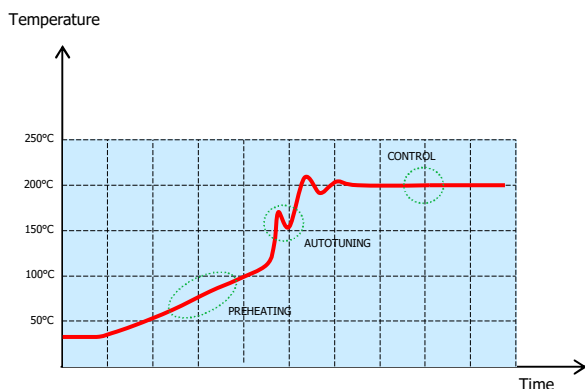

## Standard wiring output

### Multipole female connector

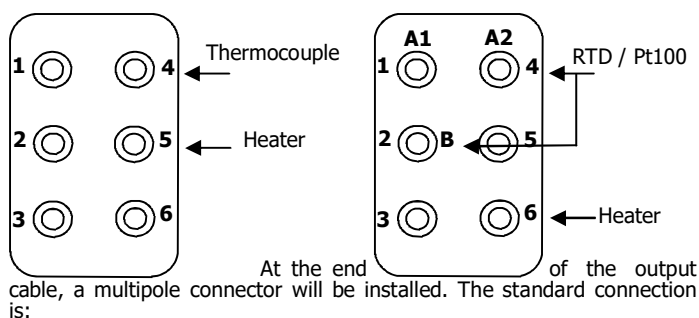

#### Thermocouple

- (+) 1 : Thermocouple positive
- (-) 4 : Thermocouple negative
- (H) 2 : Heater
- (H) 5 : Heater

#### RTD / Pt100

- 1 : A1 Pt100
- 4 : A2 Pt100
- 2 : B Pt100
- 3 : Heater
- 6 : Heater

Any other wiring output has to be specified by the customer.

## Auto tuning

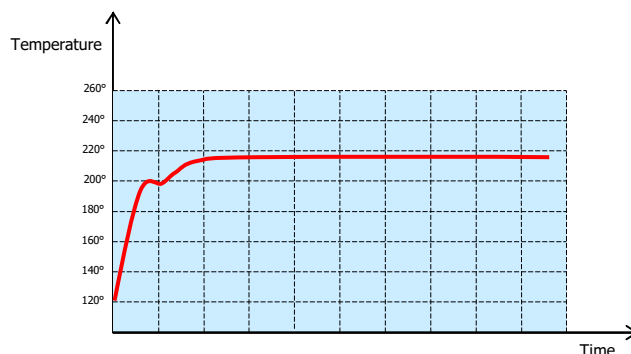

### Step Response auto tuning

It is performed when the process is below the set point value and can only be activated when the process is under the 50% of this set point.

This tuning consist on increasing the process value with an output of 100% and when it reaches the 80% of the set point, the output falls down to 0%. Then the controller, will calculate the optimum Pb, Ti and Td parameters, the PID parameters by measuring the overshoot and the response time.

## Ordering code

Model	Sensor	Alarm
AK53	1: Thermocouple 2: RTD	0: none 1: Included
AK53	2	1

Example: AK53-10

AK53 with thermocouple input and no alarm.

## Where to find us ?

### Few words about us

SENSO is a company based in Mataró at 30 Km. north of the Barcelona area.

Our activity is electronic instrumentation and sensors for temperature measurement and control. Our 60% of turnover is on the plastic injection moulding industry. In this field we have the knowledge to design and manufacture hot runner systems, hot halves, of course hot runner temperature controllers but we also offer a full maintenance service for the electrical side of the mould: mould cleaning, rewiring, spare parts replacement etc...

You will find us at:

<http://www.senso.es>

### SENSO ELECTRONICS S.L.U.

Camí del Sant Crist, 13 1B  
08302 – MATARÓ, Barcelona  
Tel: (+34) 93 759 38 85  
www.senso.es  
info@senso.es

