

PROCESS INDICATORS

Instructions Manual

CONTENTS

1. INTRODUCTION	4
1.1 General specifications	4
1.2 Form of order	5
2. INSTALLATION	6
2.1 Preliminary aspects	6
2.2 Input and output configuration	7
2.3. Panel assembly	7
3. INPUTS / OUTPUTS	8
3.1 Signal input options. Examples.	8
3.2 Configuration of the different inputs	10
3.3 Alarms.	11
3.4 Serial Communications (Optional)	13
3.5 Auxiliary analogue output(Optional)	14
4. OPERATION	16
4.1 Introduction	16
4.2 Description of the front	17
4.3 Starting	17
4.4 Loss of power supply	17
4.5 Automatic calibration of the pressure transducer	17
4.6 Tare function	18
4.7 Pressure transducer type	18
4.8 Display filtering function on presure measurement	18
4.9 Limits of the configurable parameters	19
4.10 Parameter configurable values and initial value	22
4.11 General menu diagram	25
4.12 Parameter protection	28
5 TECHNICAL SPECIFICATIONS	29
6 SPECIAL MESSAGES	31

1. INTRODUCTION

This instructions manual describes the installation and operation of the universal process indicators AK30 and AK32 models.



Read the instructions manual before starting the unit.

1.1. General specifications

The AK30 is a universal indicator with a configurable input. The AK32 is a universal indicator with two inputs for the simultaneous measurement of 2 variables, one configurable and the other for pressure transducer reading.

Standard:

- Totally configurable input for thermocouple, thermoresistance, voltage, current loop, pressure reading or extensiometric gauge (only AK30)
- 5 digit display (AK30) or double 5-digit display(AK32).
- 2 fully configurable alarms.

Optional:

- Modbus RS-485 communications module.
- Analogue output proportional to the reading on the indicator
- 24 V DC power supply for transmitter

Other:

- Format: 1/8 DIN43700 (96 x 48 mm, horizontal). Extractable from the front.
- Power supply. 85..265 V AC 50/60 Hz (optionally 21..53 V AC / V DC)
- Dimensions: 96 x 48 x 98 mm
- Panel drill holes: 91,5 x 45,5 (±0,5)
- Display:
 - AK30:
5 digits 13 mm for the process variable.

2 alarm warning lights

AK32:

Double display 5 digits 10 mm, one for each process.

2 alarm warning lights

Alarms: 2 fully configurable alarms. SPST output(1A@250 V AC)

• Weight:

AK30: 220 g.

AK32: 240 g.

• Inputs:

User-configurable as:

L : 0..600°C (Fe-CuNi, DIN43710)

J : 0..600°C (Fe-CuNi, IEC584)

K: 0..1200°C (NiCr-NiAl, IEC584)

N: 0..1200°C (NiCrSi-NiSi, IEC584)

T: 0..400°C (Cu-CuNi, IEC584)

R: 0..1600°C (Pt/13%Rh-Pt, IEC584)

S: 0..1600°C (Pt/10%Rh-Pt, IEC584)

RTD, Pt100: -200..600°C (IEC751)

RTD, Pt100: -99,9..200,0°C (IEC751)

Current loop 0..20 , 4..20 mA (load 150 ohm)

Voltage V DC 0..5 , 0..10 V (Impedance >1 Mohm)

Pressure transducer

Extensometric gauge 350 ohm(only AK30)

1.2. Form of order

Model	Options	Power supply	Language
	0: No options 1: Analogue output with AK35 2: Standard communications Modbus/RS-485 with AK36 3: 24 V DC power supply for transmitter with AK37	1: 85..265 V AC, 50/60 Hz 2: 21..53 V AC / V DC	
AK30	1	1	
AK32	1	1	

2. INSTALLATION

2.1. Preliminary aspects

The unit is connected with the instrument installed in its final place of use. To avoid electrical discharges while connecting, connect the instrument to the power supply in the last wiring operation. The installation must include at least one 1^a, 250 V bipolar switch, which must be close to the instrument and easily accessible for the operator. It must be marked as an instrument switch. Likewise, a 200 mA, 250 V fuse must be installed in the power supply wiring (isolation cable of at least 1000 V).

The following recommendations should be followed as far as possible:

- The instrument must be connected in the absence of power supply.
- Do not install the instrument close to moving parts, contacts or motor starters.
- Try to avoid mechanical vibrations.
- For the signal lines, it is recommendable to use a screened cable with a ground connection at a single point.
- It is important to check the configuration of the instrument if any problem appears in the starting.

Any installation or use of the instrument other than that specified in this manual may affect the protection levels of the unit.

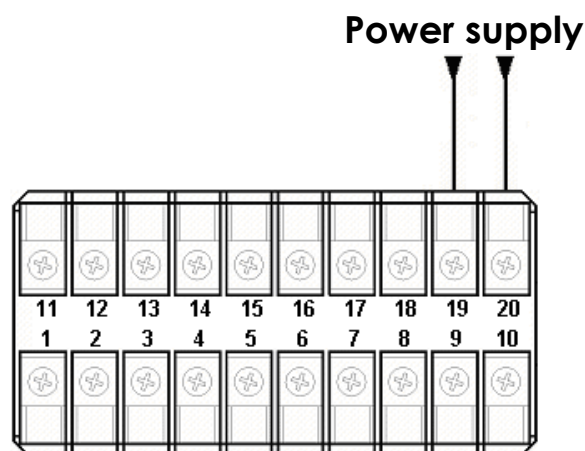

2.2. Input and output configuration

The instruments of the are entirely configurable, so it is necessary to make sure before starting that the configuration of the instrument corresponds to the application for which it is intended.

Follow the steps in chapter 3 to change the configuration of the input or sensor signal.

2.3. Panel assembly

The instrument must be installed in a panel with a maximum thickness of 8 mm. Its location must be subject to as little vibration as possible and it must be ensured that the ambient temperature remains between 0 and 50°C.

Insert the instrument in the panel hole and hold it firm while, with a screwdriver, you tighten the fixing clips on the interior wall of the panel. To install more than one instrument, a minimum separation must be left between instruments of 10 mm vertically and 20 mm horizontally.

3. INPUTS / OUTPUTS

3.1. Signal input options.Examples.

This chapter diagrammatically describes the connection of the different options for the input signal.

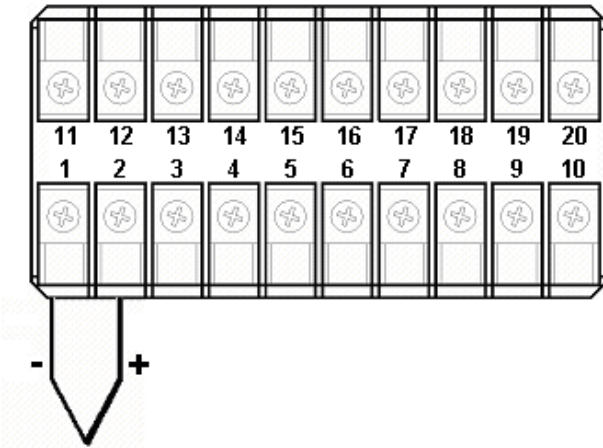

Thermocouple input connections

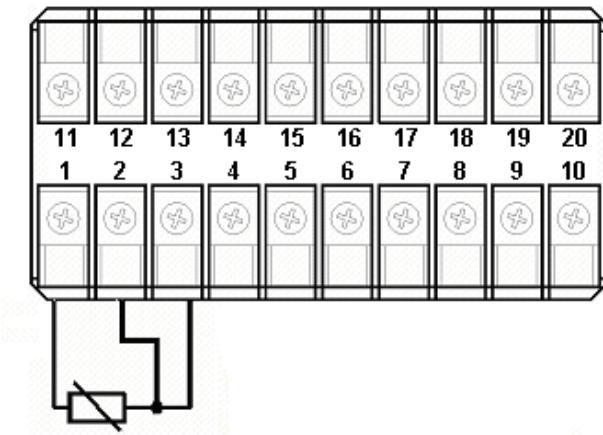

Thermoresistance input connections

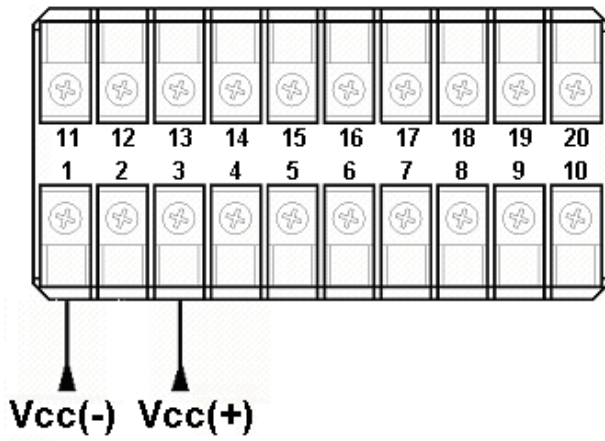

Connection for the linear voltage input

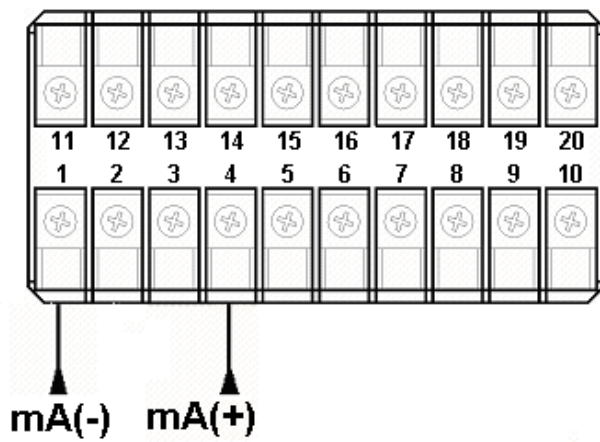

Connection for the linear current input

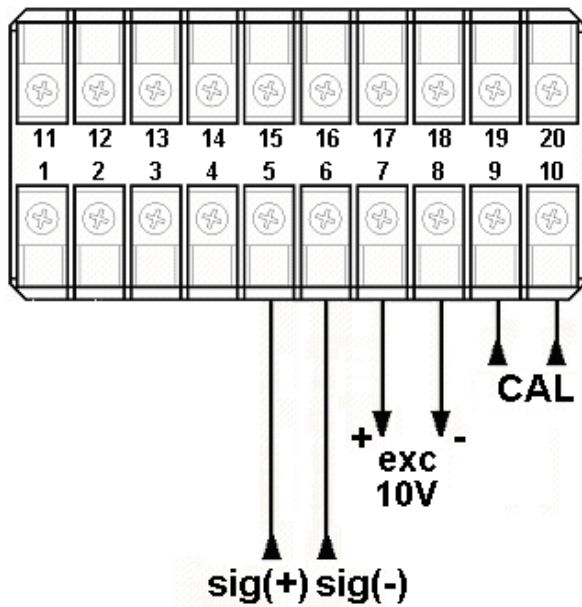

Connection for the pressure transducer input

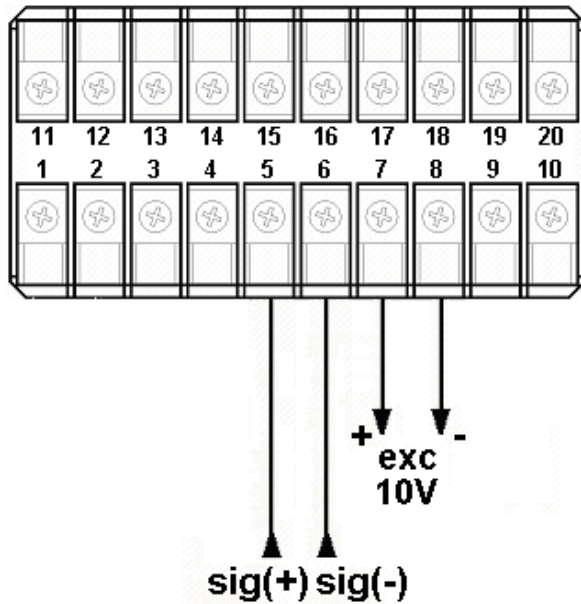

Connection for the extensometric gauge input

3.2 Configuration of the different inputs

Each instrument is default configured for a type J input (Fe-CuNi). It is possible to change the set-up of the type of input simply with the **INP** parameter from the menu. In the AK32, the second channel always shows the reading of the pressure transducer.

INP Value	Meaning
0	J : 0..600°C (Fe-CuNi, IEC584)
1	L : 0..600°C (Fe-CuNi, DIN43710)
2	K: 0..1200°C (NiCr-NiAl, IEC584)
3	N: 0..1200°C (NiCrSi-NiSi, IEC584)
4	T: 0..400°C (Cu-CuNi, IEC584)
5	R: 0..1600°C (Pt/13%Rh-Pt, IEC584)
6	S: 0..1600°C (Pt/10%Rh-Pt, IEC584)
7	RTD, Pt100: -200..600°C (IEC751)
8	RTD, Pt100: -99,9..200,0°C (IEC751)
9	Voltage V DC 0..5 V (Impedance >1 Mohm)
10	Voltage V DC 0..10 V (Impedance >1 Mohm)
11	Current loop 0..20 mA (load 150 ohm)
12	Current loop 4..20 mA (load 150 ohm)
13	Pressure transducer (only AK30)
14	Extensometric gauge 350 ohm(only AK30)

3.3 Alarms.

The AK30 and AK32 include 2 alarms. In the case of the AK32, these alarms may be associated independently with the required channel using the **Ch.A1** and **Ch.A2** parameters. Channel 1 corresponds to the configurable input and channel 2 to the pressure input. The alarm output is by relay with SPST contacts (one voltage-free contact). The alarm outputs are as follows:

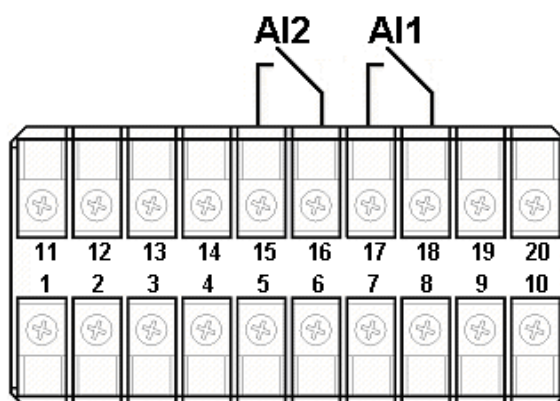

The working configuration of the alarms is performed by means of the **C.A1** and **C.A2** parameters.

1) Type of activation.

High Alarm: The alarm is activated when the process variable is equal to or higher than the consignment point of the alarm. For instance, if the consignment point of the alarm is at 450°C, the alarm will remain on as long as the temperature is greater than or equal to 450°C.

Low Alarm: The alarm is activated when the process variable is equal to or lower than the consignment point of the alarm. For instance, if the consignment point of the alarm is at 450°C, the alarm will remain on as long as the temperature is lower than or equal to 450°C.

2) Type of action.

Direct Action: The output relay is usually off and is activated when the alarm activation condition is caused.

Inverse Action: The output relay is usually on and is deactivated when the alarm activation condition is caused.

By combining the type of activation and the type of action, it is possible to configure the following alarm operation modes:

Configuration C.A1/2	Working mode
0	Alarm disabled
1	High alarm, direct action
2	High alarm, inverse action
3	Low alarm, direct action
4	Low alarm, inverse action

The alarm hysteresis can be set up using the **HY.A1** or **HY.A2** parameter. This hysteresis is used so that an activated alarm is not deactivated until the margin indicated from the consignment point has been exceeded. The following graphs show the behaviour of a high and low alarm with hysteresis.

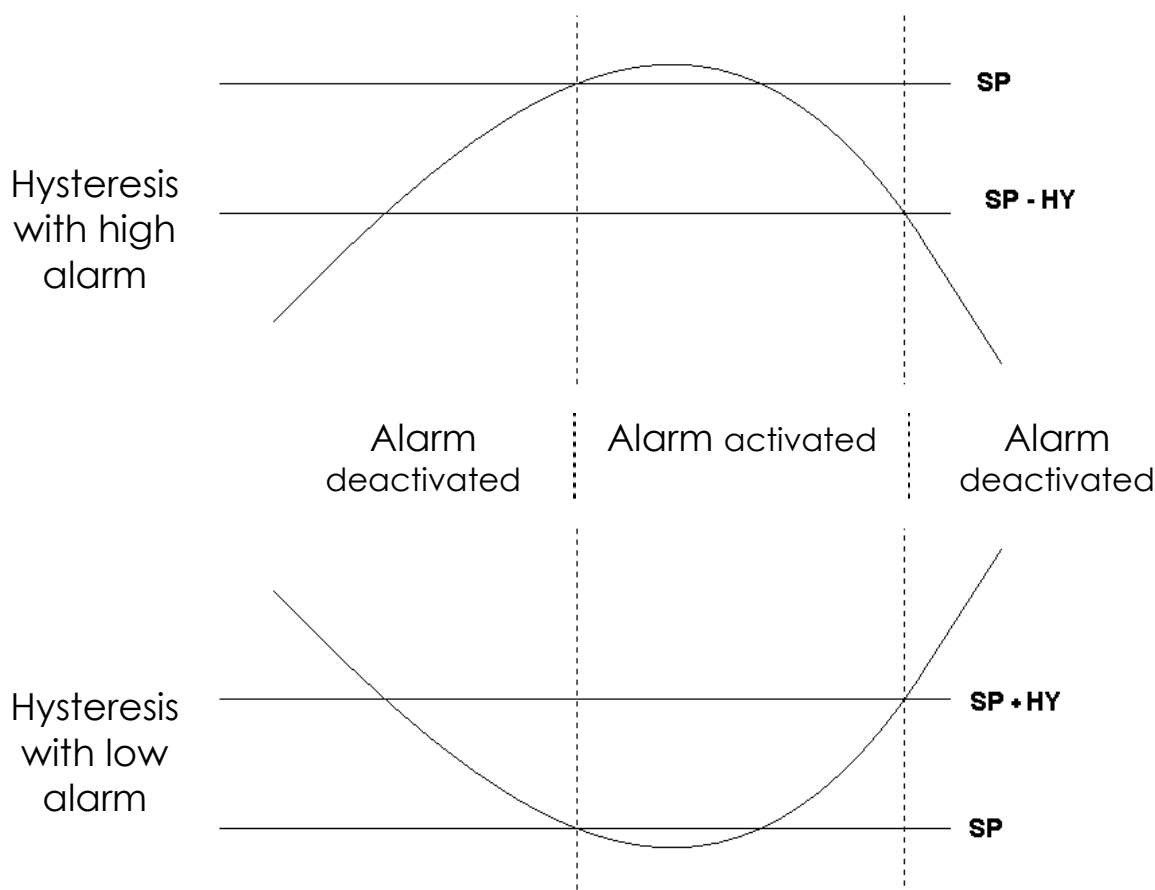

The activation of each alarm may be set up so that it is only activated once the activation condition has been fulfilled for a period of

time of up to 20 seconds. This is achieved using the **dLy.A1** and **DLY.A2** parameters. If these parameters are 0, the activation is instantaneous.

Also included is a working mode where the alarm is kept off while the alarm condition is not fulfilled (masked alarm). Once the alarm condition is not fulfilled for the first time, the alarm works as normal. This is useful when a low alarm is configured and we do not want it to be activated until a working area has been entered. This working mode is activated with the **NAs.A1** and **NAs.A2** parameters. Once activated, this mode is entered without the instrument having to be turned on once more. When the instrument is turned on again, this mode will be started.

The alarm deactivation may be set up as manual or automatic. If an alarm is triggered with manual deactivation, it will not be deactivated until the instrument is told explicitly. This configuration is performed with the **Lch.A1** and **Lch.A2** parameters. To activate the alarm manually, the ▲ and ▼ keys must be pressed simultaneously.

3.4 Serial Communications (Optional)

The serial communications interface is RS485, 2 strands + ground, half duplex. Once installed, this interface is activated on assigning the **Opt** parameter to 1.

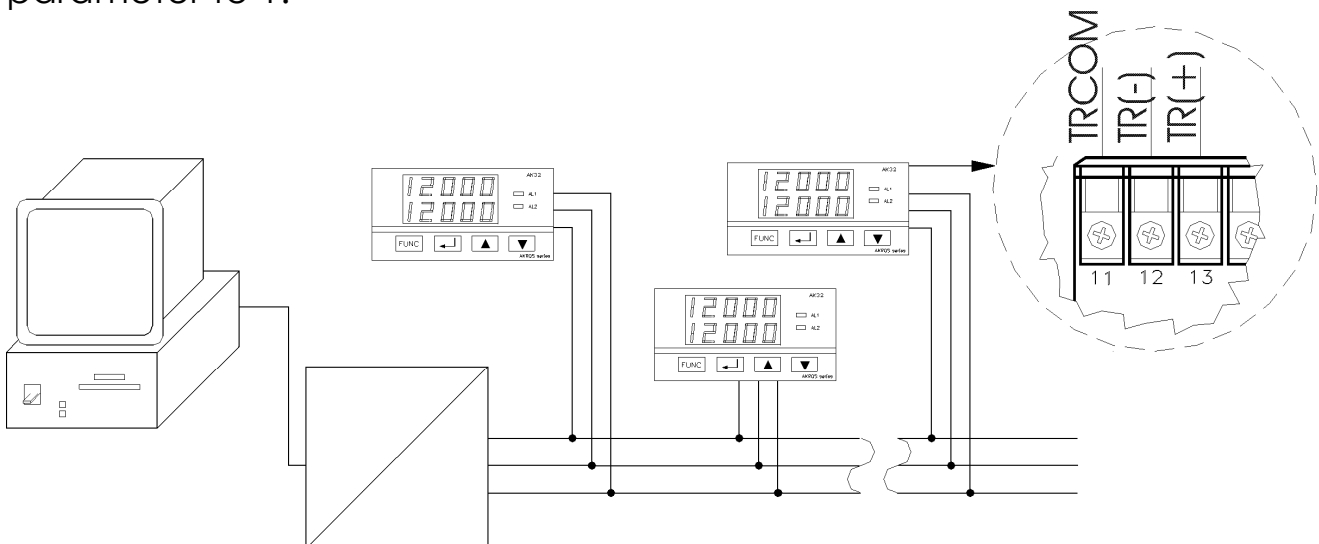

There is a specific instructions manual for the interface and communications protocol.

3.5 Auxiliary analogue output(Optional)

The auxiliary analogue output may be 0..20 mA, 4..20 mA, 0..5 V or 0..10 V and the option must be configured both in the module provided and in the indicator. Once installed, this interface is activated on assigning the value 2(0..20 mA), 3(4..20 mA), 4(0..5 V) or 5(0..10 V) to the **Opt** parameter.

Once activated, the analogue output may be set up as direct or inverse and the variation margin of the signal may also be set up by the user.

Direct Output (**AOut.S** = 1) means that the value of the output signal increases along with the process variable.

Inverse Output (**AOut.S** = 0) means that the value of the output signal falls as the process variable increases.

Likewise, it is possible to set up the minimum (**AOut.L**) and maximum (**AOut.H**) value of the process variable between which the analogue output will vary between its minimum and maximum.

For example, an instrument with a type J thermocouple input has a scale of 0..600°C. If this instrument has an analogue output of 4..20 mA, it is possible to set up **AOut.L** = 100°C and **AOut.H** = 500°C with which the analogue output will take the following values:

Process (°C)	Direct Analogue Output (mA)	Inverse Analogue Output (mA)
0	4,0	20,0
100	4,0	20,0
200	8,0	16,0
300	12,0	12,0
400	16,0	8,0
500	20,0	4,0
600	20,0	4,0

In the Ak32, it is possible to set the channel associated to the digital output by means of the **Set.Ch** parameter. Channel 1 corresponds to the configurable input and channel 2 corresponds to the pressure input.

4. OPERATION

4.1 Introduction

The indicators may be completely set up by means of a series of parameters accessible from a menu. The availability of some parameters depends on the current set-up of the instrument and the model. Point 4.7 describes all the configurable parameters and point 4.9 graphically displays the route necessary to access each of the parameters.

The operation of the menus is controlled by means of 4 keys with the following function:

FUNC: Function key. It is used to enter the menu or to pass to the following parameter if we are already in this menu.

▲: It serves to increase the value of a parameter. If it is held down, every 10 increments the speed of the increase rises. In the case of an AK30 set up as an extensiometric reader, if it is held down for 3 seconds from outside the menu, the value of the current reading is taken as a Tare. When the instrument is applying a tare, this is indicated by means of a point that flashes on the last digit.

▼: It serves to decrease the value of a parameter. If it is held down, every 10 decreases the speed of the decrease rises. In the case of an AK30 set up as an extensiometric reader, if it is held down for 3 seconds from outside the menu, the value of the Tare is eliminated.

▣: Confirmation key. This must be pressed each time a change made to a parameter is to be confirmed. The instrument will flash to indicate that the parameter has been saved. All of the parameters that depend on the modified parameter are updated in order to be consistent. If it is held down in an AK30 set up as a pressure transducer reader or in an AK32, we enter the automatic transducer calibration mode. At the end of this mode, confirmation is requested of the new calibration.

4.2 Description of the front

In addition to the front keys described in the previous aside, there are 2 alarm warning lights labelled as AL1 and AL2.

4.3 Starting

On connecting the power supply, the instrument shows the message **tEst** moving through the displays while all the internal parameters are started.

4.4 Loss of power supply

All of the working parameters of the instrument are stored in an internal memory. When the power supply returns, it will return to the operating mode in which it was before.

4.5 Automatic calibration of the pressure transducer

This indicator has an automatic self-calibration function for pressure transducers that enable this. In the AK-32, this function is always available, whereas in the AK-30 it is only available when the input probe is set up as a pressure transducer (**InP** = 13).

To activate the self-calibration, the  must be held down for 3 seconds. Firstly, the zero value of the transducer is calibrated, and then the value of 80% of the scale base. If the transducer is subject to pressure when the zero value is calibrated, the calibration will not be correct.

At the end of the self-calibration, the message **SAUE** appears if the measurements taken are correct. By pressing  the new calibration is confirmed, whereas by pressing **FUNC** , it is discarded. If the measurement taken in the zero and that taken at 80% of the scale base are not correct, the **FAiL** message appears.

4.6 Tare function (only available in AK-30 using an extensimetric gauge)

This indicator allows a tare to be added to the measurement when it is set up with a gauge input. To activate a new tare, hold down the **▲** key. Once activated, the **tAr.On** message appears and the decimal point of the last digit flashes, indicating that the indicator is adjusted. To deactivate the tare, press the **▼** key for 3 seconds. On deactivating it, the **tAr.Of** message appears.

4.7 Pressure transducer type

The **tyPE** parameter let you chose between 3 different pressure transducer types with different input margins and auto-calibration options. The following table shows the meaning of the different values from **tyPE**.

tyPE	Meaning
0	Pressure transducer with input margin from -3 mV to 37 mV and auto-calibration of 0 and 80%
1	Pressure transducer with input margin from 0 mV to 100 mV and auto-calibration of 0 and 80%
2	Pressure transducer with input margin from 0 mV to 100 mV and auto-calibration of 0%

4.8 Display filtering function on presure measurement

Setting the **Filtr** parameter to 1 activates filtering the value shown in the display when measuring pressure. The objective of this filter is to make the displayed measure more stable when working on fast changing enviroments. The filter only affects to the displayed measurement, that is, other functions still use the real measured signal(alarm activation, analog output,...).

4.9 Límites de los parámetros configurables

SP.A1	<p>Alarm consignment point 1</p> <p>Minimum value:</p> <table data-bbox="638 336 1340 537"> <tr> <td>Probe selected</td> <td>Value</td> </tr> <tr> <td>Thermocouple</td> <td>Minimum probe value</td> </tr> <tr> <td>Thermoresistance</td> <td>Minimum probe value</td> </tr> <tr> <td>Linear input(V o mA)</td> <td>in.L parameter</td> </tr> <tr> <td>Pressure transducer</td> <td>-10% scale base</td> </tr> <tr> <td>Extensiometric gauge (AK30)</td> <td>0</td> </tr> </table> <p>Maximum value:</p> <table data-bbox="638 560 1340 761"> <tr> <td>Probe selected</td> <td>Valor</td> </tr> <tr> <td>Thermocouple</td> <td>Maximum probe value</td> </tr> <tr> <td>Thermoresistance</td> <td>Maximum probe value</td> </tr> <tr> <td>Linear input(V o mA)</td> <td>in.H parameter</td> </tr> <tr> <td>Pressure transducer</td> <td>FSV</td> </tr> <tr> <td>Extensiometric gauge(AK30)</td> <td>FSV</td> </tr> </table>	Probe selected	Value	Thermocouple	Minimum probe value	Thermoresistance	Minimum probe value	Linear input(V o mA)	in.L parameter	Pressure transducer	-10% scale base	Extensiometric gauge (AK30)	0	Probe selected	Valor	Thermocouple	Maximum probe value	Thermoresistance	Maximum probe value	Linear input(V o mA)	in.H parameter	Pressure transducer	FSV	Extensiometric gauge(AK30)	FSV
Probe selected	Value																								
Thermocouple	Minimum probe value																								
Thermoresistance	Minimum probe value																								
Linear input(V o mA)	in.L parameter																								
Pressure transducer	-10% scale base																								
Extensiometric gauge (AK30)	0																								
Probe selected	Valor																								
Thermocouple	Maximum probe value																								
Thermoresistance	Maximum probe value																								
Linear input(V o mA)	in.H parameter																								
Pressure transducer	FSV																								
Extensiometric gauge(AK30)	FSV																								
SP.A2	<p>Alarm consignment point 2</p> <p>Minimum value:</p> <table data-bbox="638 873 1340 1075"> <tr> <td>Probe selected</td> <td>Value</td> </tr> <tr> <td>Thermocouple</td> <td>Minimum probe value</td> </tr> <tr> <td>Thermoresistance</td> <td>Minimum probe value</td> </tr> <tr> <td>Linear input(V o mA)</td> <td>in.L parameter</td> </tr> <tr> <td>Pressure transducer</td> <td>-10% scale base</td> </tr> <tr> <td>Extensiometric gauge(AK30)</td> <td>0</td> </tr> </table> <p>Maximum value:</p> <table data-bbox="638 1097 1340 1299"> <tr> <td>Probe selected</td> <td>Value</td> </tr> <tr> <td>Thermocouple</td> <td>Maximum probe value</td> </tr> <tr> <td>Thermoresistance</td> <td>Maximum probe value</td> </tr> <tr> <td>Linear input(V o mA)</td> <td>in.H parameter</td> </tr> <tr> <td>Pressure transducer</td> <td>FSV</td> </tr> <tr> <td>Extensiometric gauge(AK30)</td> <td>FSV</td> </tr> </table>	Probe selected	Value	Thermocouple	Minimum probe value	Thermoresistance	Minimum probe value	Linear input(V o mA)	in.L parameter	Pressure transducer	-10% scale base	Extensiometric gauge(AK30)	0	Probe selected	Value	Thermocouple	Maximum probe value	Thermoresistance	Maximum probe value	Linear input(V o mA)	in.H parameter	Pressure transducer	FSV	Extensiometric gauge(AK30)	FSV
Probe selected	Value																								
Thermocouple	Minimum probe value																								
Thermoresistance	Minimum probe value																								
Linear input(V o mA)	in.L parameter																								
Pressure transducer	-10% scale base																								
Extensiometric gauge(AK30)	0																								
Probe selected	Value																								
Thermocouple	Maximum probe value																								
Thermoresistance	Maximum probe value																								
Linear input(V o mA)	in.H parameter																								
Pressure transducer	FSV																								
Extensiometric gauge(AK30)	FSV																								
C.A1	<p>Alarm configuration 1</p> <p>Minimum value: 0</p> <p>Maximum value: 4</p>																								
C.A2	<p>Alarm configuration 2</p> <p>Minimum value: 0</p> <p>Maximum value: 4</p>																								
Hy.A1	<p>Alarm hysteresis 1 (only visible if C.A1 ≠ 0)</p> <p>Minimum value: 0</p> <p>Maximum value:</p> <table data-bbox="638 1612 1340 1680"> <tr> <td>If alarm configured low</td> <td>SP.A1 – Probe Low Limit</td> </tr> <tr> <td>If alarm configured high</td> <td>Probe High Limit – SP.A1</td> </tr> </table>	If alarm configured low	SP.A1 – Probe Low Limit	If alarm configured high	Probe High Limit – SP.A1																				
If alarm configured low	SP.A1 – Probe Low Limit																								
If alarm configured high	Probe High Limit – SP.A1																								
Hy.A2	<p>Alarm hysteresis 1 (only visible if C.A2 ≠ 0)</p> <p>Minimum value: 0</p> <p>Maximum value:</p> <table data-bbox="638 1814 1340 1881"> <tr> <td>If alarm configured low</td> <td>SP.A1 – Probe Low Limit</td> </tr> <tr> <td>If alarm configured high</td> <td>Probe High Limit – SP.A1</td> </tr> </table>	If alarm configured low	SP.A1 – Probe Low Limit	If alarm configured high	Probe High Limit – SP.A1																				
If alarm configured low	SP.A1 – Probe Low Limit																								
If alarm configured high	Probe High Limit – SP.A1																								

Ch.A1	Alarm channel 1 (only visible in AK32 if C.A1 ≠ 0) Minimum value: 1 Maximum value: 2
Ch.A2	Alarm channel 2 (only visible in AK32 if C.A2 ≠ 0) Minimum value: 1 Maximum value: 2
Mas.A1	Alarm mask 1 (only visible if C.A1 ≠ 0) Minimum value: 0 Maximum value: 1
Mas.A2	Alarm mask 2 (only visible if C.A2 ≠ 0) Minimum value: 0 Maximum value: 1
dLy.A1	Alarm wait 1 (only visible if C.A1 ≠ 0) Minimum value: 0 Maximum value: 300
dLy.A2	Alarm wait 2 (only visible if C.A2 ≠ 0) Minimum value: 0 Maximum value: 300
Lch.A1	Alarm manual deactivation 1 (only visible if C.A1 ≠ 0) Minimum value: 0 Maximum value: 1
Lch.A2	Alarm manual deactivation 2 (only visible if C.A2 ≠ 0) Minimum value: 0 Maximum value: 1
Bias1	Channel bias 1 Minimum value: -9999 Maximum value: 99999
Bias2	Channel bias 2(only visible in AK32) Minimum value: -9999 Maximum value: 99999
INP	Channel input probe 1 Minimum value: 0 Maximum value: 14 in AK30 12 in AK32
Unit	Unit (only visible if INP ≤ 8) Minimum value: 0 Maximum value: 1
Dp	Position of the decimal point (only visible if INP ≥ 9) Minimum value: 0 Maximum value: 3
in.L	A lower value for the scale of linear signal inputs (only visible if INP = 9, 10, 11, 12) Minimum value: -9999 Maximum value: in.H -1
in.H	A higher value for the scale of linear signal inputs (only visible if INP = 9, 10, 11, 12) Minimum value: in.L + 1 Maximum value: 99999

FSV	Pressure input or extensimetric gauge scale base value (only visible in AK30 if Inp >= 13. Always visible in AK32) Minimum value: 0 Maximum value: 1
Type	Pressure transducer type Minimum value: 0 Maximum value: 2
Filtr	activación del filtro de visualización de presión Minimum value: 0 Maximum value: 1
Zero.S	Gauge zero voltage (only visible in AK30 if INP = 14) Minimum value: -3.00 Maximum value: FSV.S – 0.01
FSV.S	Maximum gauge voltage (only visible in AK30 if INP = 14) Minimum value: Zero.S + 0.01 Maximum value: 37.00
Opt	Optional functions Minimum value: 0 Maximum value: 5
Set.Ch	Analog output associated channel (only visible if Opt >= 2) Minimum value: 1 Maximum value: 2
AOut.S	Analogue output sign (only visible if Opt >= 2) Minimum value: 0 Maximum value: 1
AOut.L	Analogue output low limit (only visible if Opt >= 2) Minimum value: channel probe minimum Maximum value: AOut.H – 1
AOut.H	Analogue output high limit (only visible if Opt >= 2) Minimum value: AOut.L - 1 Maximum value: channel probe maximum
Addr	Modbus address (only visible if Opt = 1) Minimum value: 0 Maximum value: 240
Speed	Transmission speed (only visible if Opt = 1) Minimum value: 0 Maximum value: 3
Prty	Transmission parity (only visible if Opt = 1) Minimum value: 0 Maximum value: 2
Dlay	Modbus delay (only visible if Opt = 1) Minimum value: 0 Maximum value: 10
Pass	Password Minimum value: 0 Maximum value: 99999
Level	Security level Minimum value: 0 Maximum value: 1

4.10 Parameter configurable values and initial value

Parameter	Meaning	Initial value	
SP.A1	Alarm consignment point 1	100	
SP.A2	Alarm consignment point 2	200	
C.A1	Alarm configuration 1		0
	Value	Meaning	
	0	Alarm disabled	
	1	Direct high alarm	
	2	Inverse high alarm	
	3	Direct low alarm	
C.A2	Alarm configuration 2		0
	Value	Meaning	
	0	Alarm disabled	
	1	Direct high alarm	
	2	Inverse high alarm	
	3	Direct low alarm	
Hy.A1	Alarm hysteresis 1	2	
Hy.A2	Alarm hysteresis 2	2	
Ch.A1	Alarm channel 1	1	
Ch.A2	Alarm channel 2	1	
Mas.A1	Alarm mask 1 (1 = actived, 0 = deactivated)	0	
Mas.A2	Alarm mask 2 (1 = actived, 0 = deactivated)	0	
dLy.A1	Alarm wait 1	0	
dLY.A2	Alarm wait 2	0	
Lch.A1	Alarm manual deactivation 1 (1 = activated, 0 = deactivated)	0	
Lch.A2	Alarm manual deactivation 2 (1 = activated, 0 = deactivated)	0	
Bias1	Channel bias 1	0	
Bias2	Channel bias 2	0	

Inp	Channel input probe 1		0
	<i>Value</i>	<i>Meaning</i>	
	0	J : 0..600°C (Fe-CuNi, IEC584)	
	1	L : 0..600°C (Fe-CuNi, DIN43710)	
	2	K: 0..1200°C (NiCr-NiAl, IEC584)	
	3	N: 0..1200°C (NiCrSi-NiSi, IEC584)	
	4	T: 0..400°C (Cu-CuNi, IEC584)	
	5	R: 0..1600°C (Pt/13%Rh-Pt, IEC584)	
	6	S: 0..1600°C (Pt/10%Rh-Pt, IEC584)	
	7	RTD, Pt100: -200..600°C (IEC751)	
	8	RTD, Pt100: -99,9..200,0°C (IEC751)	
	9	Voltage V DC 0..5 V (Impedance >1 Mohm)	
	10	Voltage V DC 0..10 V (Impedance >1 Mohm)	
	11	Current loop 0..20 mA (load 150 ohm)	
	12	Current loop 4..20 mA (load 150 ohm)	
13	Pressure transducer(only AK30)		
14	Extensimetric gauge 350 ohm (only AK30)		
Unit	Unit		0
	<i>Value</i>	<i>Meaning</i>	
	0	°C	
	1	F	
Dp	Position of the decimal point		0
In.L	Lower value for scale of inputs of linear signals		0
In.H	Higher value for scale of inputs of linear signals		99999
FSV	Pressure scale base or extensimetric gauge		99999
Type	Pressure transducer type		0
	<i>Value</i>	<i>Meaning</i>	
	0	-3 a 37 mV transducer. Auto-calibration 0-80%	
	1	0 a 100 mV transducer. Auto-calibration 0-80%	
	2	0 a 100 mV transducer. Auto-calibration 0	
Filtr	Display value filter for pressure measurement		0
Zero.S	Gauge zero voltage value		-3.00
FSV.S	Gauge maximum voltage value		37.00
Opt	Optional functions		0
	<i>Value</i>	<i>Meaning</i>	
	0	No option	
	1	Communications module	
	2	Analogue output 0..5 V	
	3	Analogue output 0..10 V	
	4	Analogue output 0..20 mA	
5	Analogue output 4..20 mA		
Set.Ch	Channel associated with analogue output		1
AOut.S	Analogue output sign		0
	<i>Value</i>	<i>Meaning</i>	
	0	Direct output	

	1	Inverse output	
AOut.L		Analogue output low limit	0
AOut.H		Analogue output high limit	600
Addr		Modbus address	0
Speed		Transmission speed	0
Prty		Transmission parity	0
	<i>Value</i>	<i>Meaning</i>	
	0	No parity	
	1	Even parity	
	2	Odd parity	
Dlay		Modbus delay	0
Pass		Password	0
Level		Security level (deactivated if Pass = 0)	0
	<i>Value</i>	<i>Meaning</i>	
	0	The password is requested for access to any parameter following the consignment points and to perform any calibration	
	1	A password is requested for entering any menu	

4.11 General menu diagram

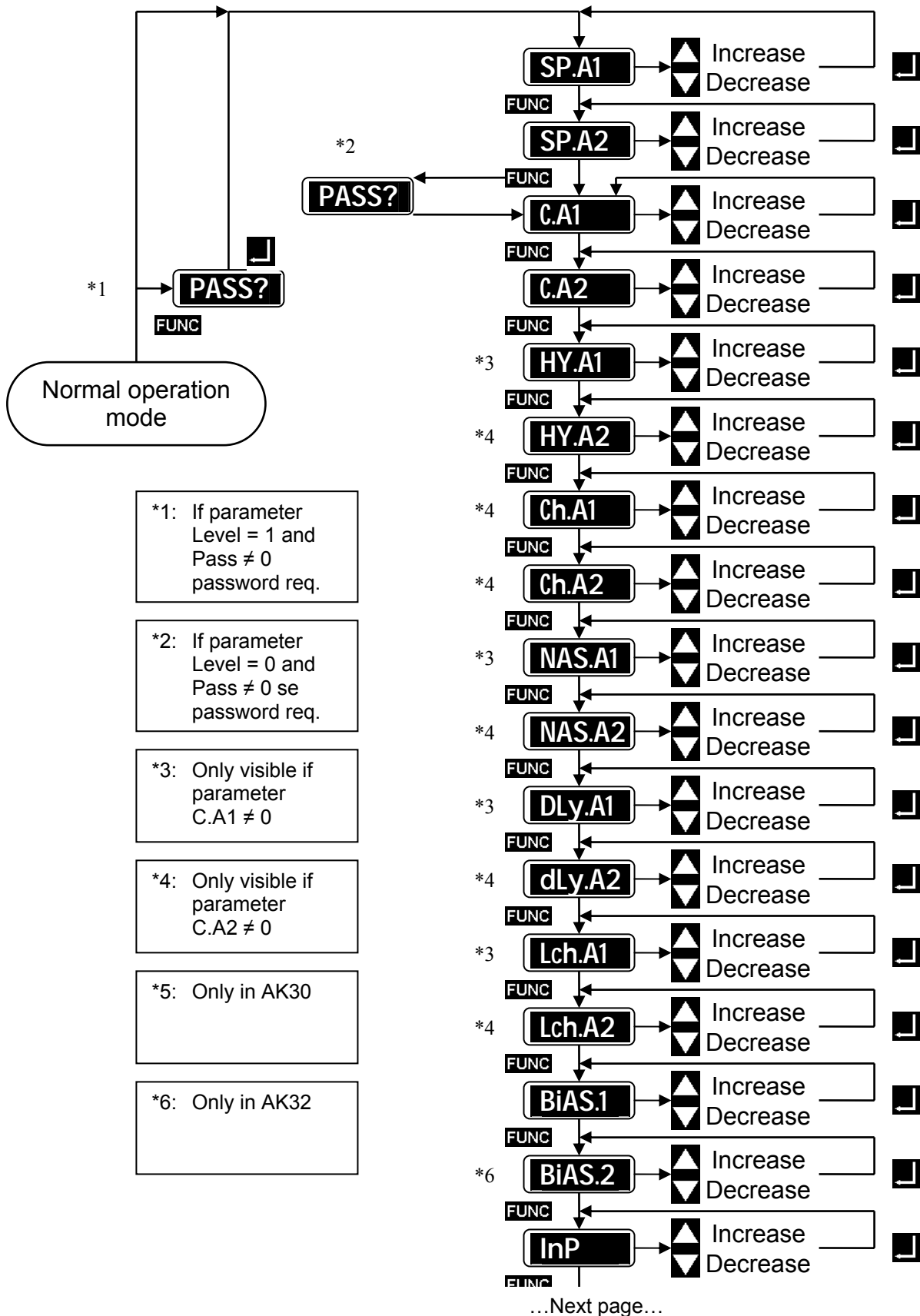

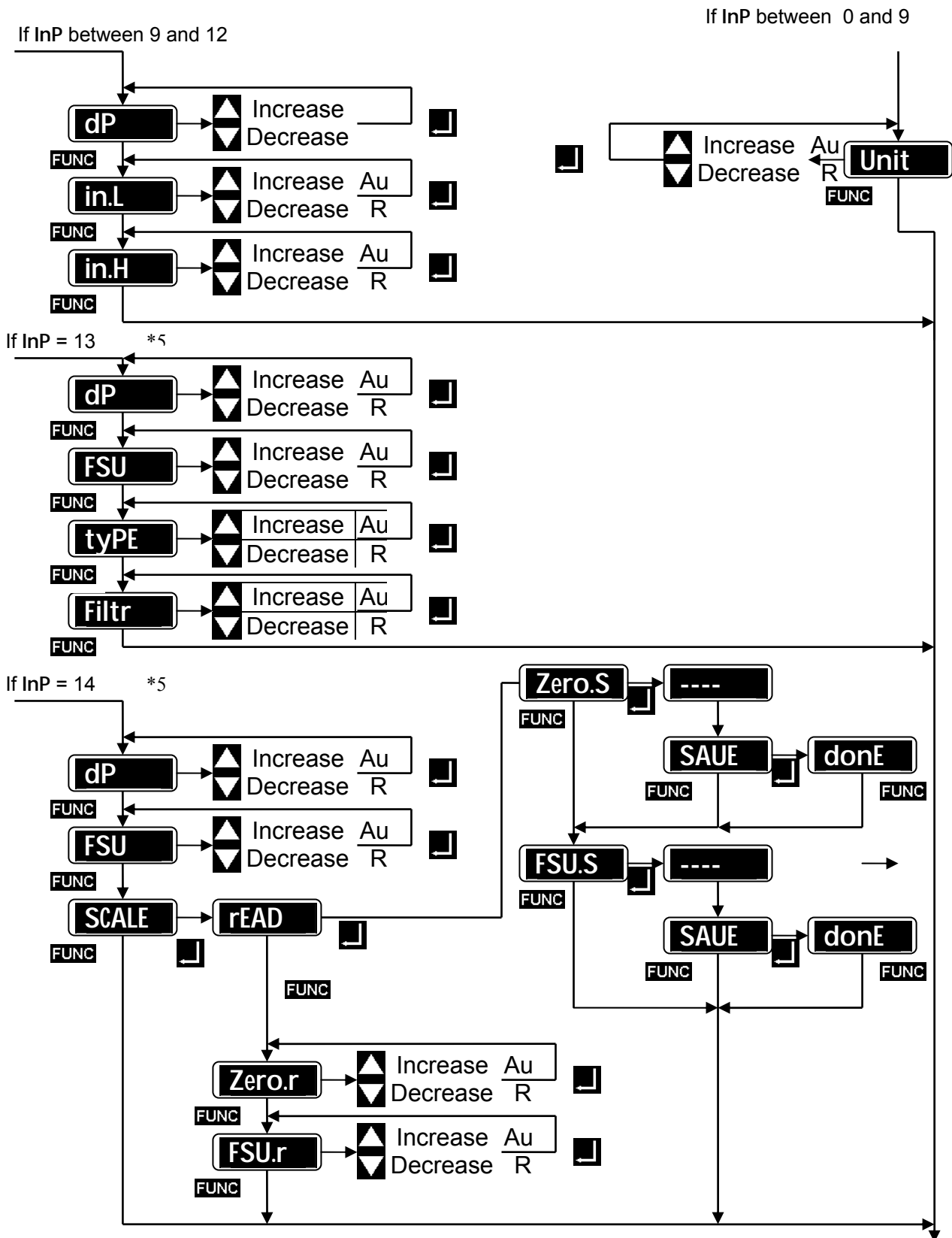

...Next page...

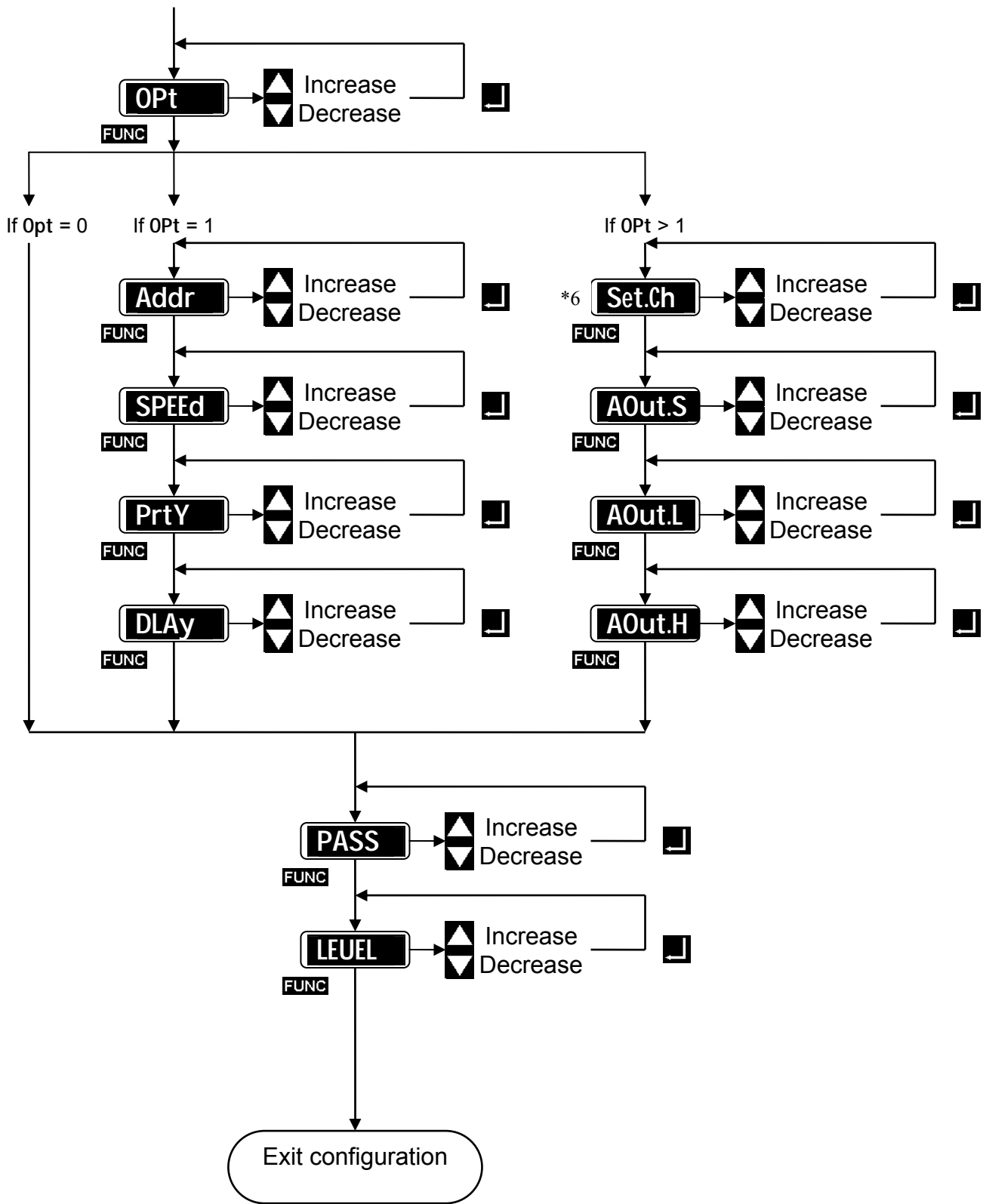

Automatic calibration of the pressure transducer

Only utilisable in AK32 or AK30 set up with pressure input (INP = 13)

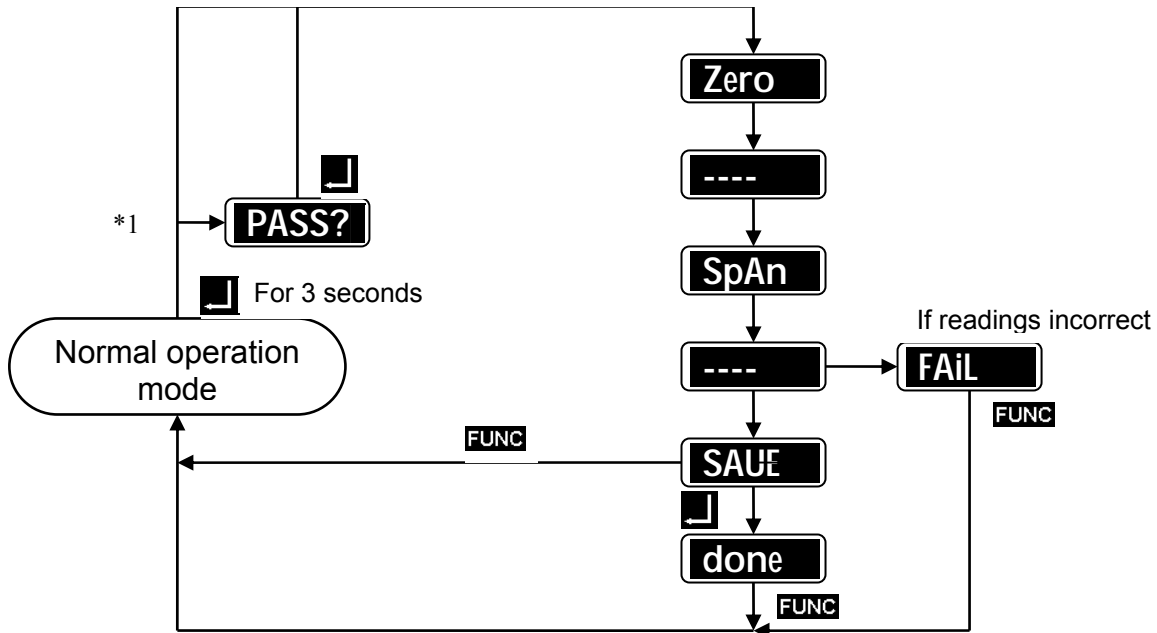

Tare activation/deactivation

Utilisable in AK30 set up with extensiometric gauge input (INP = 14)

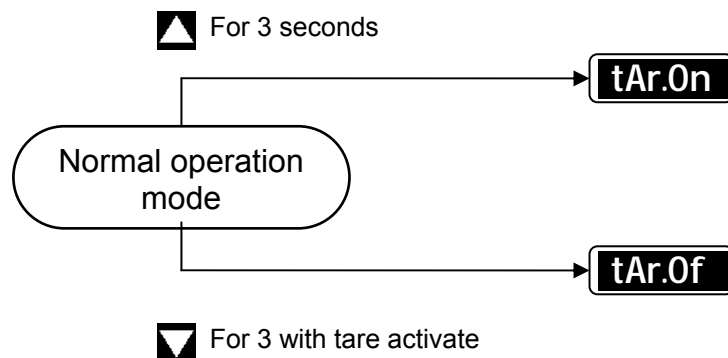

4.12 Parameter protection

By assigning a value other than 0 to the **PASS** parameter, the menu block is activated. If the **LEUEL** level is assigned to 0 the points of the consignment can be modified. If **LEUEL** is assigned to 1, they are all blocked. Once the block is activated, it is necessary to enter the assigned key in the **pASS** parameter to be able to access the menus.

5. TECHNICAL SPECIFICATIONS

Format		1/8 DIN43700 (96 x 48 mm, horizontal). Extractable from the front.
Power supply		85..265 V AC 50/60 Hz (optionally 21..53 V AC / V DC)
Consumption		8 VA
Ambient Temp.		0..50°C (use inside)
Relative humidity		max. 80% without condensation
Altitude		max. 2000 m
Installation cat.		II according to EN61010-1
Pollution grade		I according to EN61010-1
Box		ABS self-extinguishable
Dimensions		96 x 48 x 98 mm
Panel drill holes		91,5 x 45,5 (±0,5)
Display	AK30	5 digits 13 mm 2 alarm warning lights
	AK32	Double display 5 digits 10 mm 2 alarm warning lights
Inputs		User-configurable as: L : 0..600°C (Fe-CuNi, DIN43710) J : 0..600°C (Fe-CuNi, IEC584) K: 0..1200°C (NiCr-NiAl, IEC584) N: 0..1200°C (NiCrSi-NiSi, IEC584) T: 0..400°C (Cu-CuNi, IEC584) R: 0..1600°C (Pt/13%Rh-Pt, IEC584) S: 0..1600°C (Pt/10%Rh-Pt, IEC584) RTD, Pt100: -200..600°C (IEC751) RTD, Pt100: -99,9..200,0°C (IEC751) Current loop 0..20 , 4..20 mA (load 150 ohm) Voltage V DC 0..5 , 0..10 V (Impedance >1 Mohm) Pressure transducer Extensiometric gauge 350 ohm (only AK30)
Precision		0.25% v.f.e.
Analog output		(Option with AK35 module) User-configurable: 0..5V, 0..10V, 0..20mA, 4..20mA
Serial communications		(Option with AK36 module) MODBUS/RTU protocol over RS-485

Power supply for transmitter		(Option with AK37 module) 10 V DC (max. 100mA)
Alarms		2 fully configurable. SPST output (1A @ 250 V AC., resistive load)
Weight	AK30	220 g.
	AK32	240 g.
Protection		IP40 in front
CE Certification		Safety, EMI Susceptibility, EMI Emission, Harmonics, Voltage fluctuations

6. SPECIAL MESSAGES

NN.Err Reading error from internal memory. If this message is caused each time the instrument is turned on, send it to your nearest distributor for repair

Depending on the type of entry, the meaning of the **OUEr** and **UndEr** messages will vary along the following table

Input	OUEr meaning	UndEr meaning
Thermocouple	The input signal circuit has been interrupted or the input signal is above maximum.	The connection is inverted or the input signal is lower than the lower limit of the scale.
Thermoresistance	The resistance is open and the connection between terminals 2 and 3 is present, or the input signal is above maximum	Probe not connected, the connection between terminals 2 and 3 has been interrupted or the input signal is lower than the lower limit of the scale
Voltage line	The input signal is higher than the maximum limit.	The input signal circuit has been interrupted or the input signal is below the lower limit of the scale.
Current line 0..20 mA	The input signal is higher than the maximum limit.	The input signal circuit has been interrupted or the input signal is below the lower limit of the scale. UndEr is not always displayed with the input signal circuit is interrupted
Current line 4..20 mA	The input signal is higher than the maximum limit.	The input signal circuit has been interrupted or the input signal is below the lower limit of the scale.
Pressure or gauge	The input signal is higher than the maximum limit. Input is fully interrupted.	The input signal is below the lower limit of the scale.

In the event of pressure or gauge input, if the any of the input signal lines is interrupted, the indicator can show any value (including **OUEr** or **UndEr**)